

Reliable®

Model DH56 Model DH56 Recessed Model DH56 Concealed Quick Response, Extended Coverage Sprinkler

For coverages up to 28 feet wide and 10 feet long⁽¹⁾. 250 psi (17,2 bar) rated.

Features:

- Coverage for long and narrow spaces such as hallways, corridors, decks and rooms up to 28 feet wide and 10 feet long.⁽¹⁾
 - Deflector to ceiling dimensions are:
4" (102mm) min. to 12" (305mm) max.
 - Minimum spacing between sprinklers
14 feet (4.3m).
 - Polyester Coated Corrosion Resistant Sprinklers (cULus)
 - UL Listed for extended coverage, light hazard applications.
 - 5.6 K Factor.
 - Sprinkler is approved for
250 psi (17,2 bar) applications.
 - Quick response performance.
 - ½" (13mm) adjustment of escutcheon and cover.
 - Concealed cover plate can prevent the sprinkler from being used for unintended purposes. No exposed thermal element with the concealed version.
 - Push-on/thread-off sturdy convenient escutcheon for recessed and cover for concealed.
 - Factory assembled sprinkler & cup, shipped complete with protective cap for concealed and FP recessed versions.
 - Sprinkler & cup assembly and escutcheon or cover are separately packaged.
 - Cover finishes available in standard white paint, special bronze, black paint or flat white paint.
- ⁽¹⁾ See Figure 4.

Approval Organizations

- Listed by Underwriters Laboratories Inc. and UL certified for Canada (cULus)
- NYC MEA 258-93-E



DH56

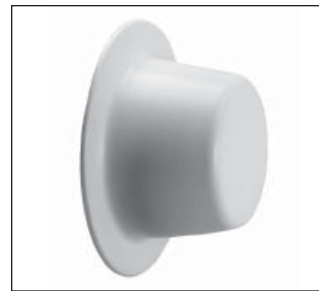
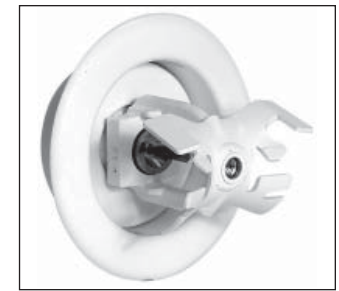

DH56 FP Recessed

DH56 Concealed
with SWC coverplate

DH56 F2 Recessed

Products Description

The Model DH56 family of sprinklers are quick response extended coverage sidewall sprinklers for use in light hazard applications. The Model DH56 with SWC cover plate is a concealed sprinkler that uses Reliable's push on/thread off sidewall cover. This sprinkler has the cup factory mounted and is shipped with a protective cap that protects the 3mm frangible glass bulb during shipping and post installation finishing operations. The DH56 can be combined in the field with the FP or F2 Escutcheon to make a recessed sprinkler. The SWC cover plate, FP and F2 recessed escutcheons have ½" adjustment. The SWC cover plate is attached with 135-degree solder. In the event of a fire the rising ambient temperature melts the solder and the cover plate is ejected away by springs exposing the 3mm frangible glass bulb. The use of a 3mm bulb allows quick response which enables the sprinkler to apply water to a fire sooner than standard response sprinklers of the same temperature rating.

Application

The Model DH56 is a horizontal sidewall sprinkler intended for installation in light hazard occupancies in accordance with NFPA 13. These sprinklers are designed to provide fire protection in long and narrow spaces such as hallways, corridors, decks and rooms up to 28 feet (8,5m) wide and 10 feet (3m) long. They are rated for 250 psi (17,2 bar) and can be mounted between 4 and 12 inches (102 and 305mm) down from the ceiling.

Installation

DH56 Recessed, FP Escutcheon

To install the DH56 with the FP Escutcheon as a recessed sprinkler cut a 2 5/8" diameter hole in the wall as shown in Figure 1. Remove temporarily the plastic protective cap, then use the GFR2 wrench to tighten the sprinkler until secured in the sprinkler fitting. NOTE: The GFR2 wrench has a notch in it to accommodate the deflector top. This wrench can only be inserted one way. Care must be taken not to damage the deflector during tightening. Apply a Teflon* based sealant to the sprinkler threads before installing in the fitting. When inserting or removing the wrench from the sprinkler cup, care must be taken to prevent damage to the sprinkler. Wrench only on the square boss. DO NOT WRENCH ON ANY OTHER PART OF THE SPRINKLER. It is recommended that the sprinkler be protected during plastering and painting operations by reinstalling the protective cap P/N 6802710003. Installation is completed by removing the protective cap and inserting the push-on escutcheon. Turn clockwise to adjust the escutcheon against the wall.

DH56 Recessed, F2 Escutcheon

To install the DH56 with the F2 Escutcheon as a recessed sprinkler cut a 2 1/4" diameter hole in the wall as shown in Figure 2. Thread the DH80 into the collar hand tight. Apply a Teflon* based sealant to the sprinkler threads and install in the fitting. Wrench only on the square boss. NOTE: The GFR2 wrench has a notch in it to accommodate the deflector top. This wrench can only be inserted one way. When inserting or removing the wrench from the sprinkler cup care must be taken to prevent damage to the sprinkler. DO NOT WRENCH ON ANY OTHER PART OF THE SPRINKLER. It is recommended that the sprinkler be protected during plastering and painting operations by using the protective cap P/N 6999991009. These must be ordered separately. Installation is completed by removing the protective cap and inserting the F2 Escutcheon over the collar.

DH56 with SWC Cover Plate Concealed

To install the sprinkler, cut a 2 5/8" diameter hole into the wall as shown in Figure 1. A Teflon* based thread sealant should be applied to the sprinkler threads only. Remove the protective cap (P/N 6802710003) and then position the GFR2 wrench into the sprinkler/cup assembly until the wrench engages the flats of the square boss. Then tighten the sprinkler into the pipe fitting. When inserting or removing the wrench from the sprinkler/cup assembly, care should be taken to prevent damage to the sprinkler. DO NOT WRENCH ON ANY OTHER PART OF THE SPRINKLER. The protective caps should be reinstalled for protection during plastering and painting. Remove caps only when covers are being installed. The cover assembly is then pushed onto the cup. Cover assemblies provide 1/2" (13mm) of adjustment. Final adjustment is made by turning the cover clockwise until the skirt flange makes full contact with the wall surface. Cover removal requires turning in the counter-clockwise direction.

Concealed cover/cup assemblies are listed only for use with specific sprinklers. The use of any other concealed cover/cup assembly with the Model DH56 Horizontal Side-wall Sprinkler or the use of the concealed cover assembly on any sprinkler with which it is not specifically listed will void all guarantees, warranties, listings and approvals.

Note: DH56 and DH56 Recessed Sprinklers have orange bulb protectors to minimize bulb damage during shipping, handling, and installation. REMOVE THIS PROTECTION AT THE TIME THE SPRINKLER SYSTEM IS PLACED IN SERVICE FOR FIRE PROTECTION. Removal of the protectors before this time may leave the bulb vulnerable to damage. RASCO wrenches are designed to install sprinklers when covers are in place. REMOVE PROTECTORS BY UNDOING THE CLASP BY HAND. DO NOT USE TOOLS TO REMOVE THE PROTECTORS.

Technical Data ⁽¹⁾:

| K Factor | | Thread Size | Temperature Rating | | Maximum Ambient Temperature | Sprinkler Identification Number (SIN) |
|----------|--------|---------------|--------------------|--------------|-----------------------------|---------------------------------------|
| US | Metric | | Sprinkler | SWC Cover | | |
| 56 | 80 | 1/2" NPT R1/2 | 155°F (68°C) | 135°F (57°C) | 100°F (38°C) | RA1564 |
| | | | 175°F (79°C) | 165°F (74°C) | 150°F (66°C) | |
| | | | 200°F (93°C) | 165°F (74°C) | 150°F (66°C) | |

⁽¹⁾ Minimum spacing of 14 feet (4,3m).

| Coverage Area | | |
|--|-----------------------|--------------------|
| Maximum Coverage Area Width x Length ft x ft (m x m) | Flow Rate gpm (L/min) | Pressure psi (bar) |
| 28 x 8 (8,5 x 2,4) | 23 (87,1) | 16.9 (1,2) |
| 28 x 10 (8,5 x 3) | 28 (106) | 25 (1,7) |

Approval Type:

- Quick Response, Extended Coverage.
- Approved for installation in accordance with NFPA 13 for light hazard occupancies.

Maintenance

Model DH56 should be inspected quarterly and the sprinkler maintained in accordance with NFPA 25. Do not clean sprinklers with soap and water, ammonia or any other cleaning fluids. Remove dust by using a soft brush or gentle vacuuming. Remove any sprinkler/cover assembly, which has been painted (other than factory applied) or damaged in any way. A stock of spare sprinklers should be maintained to allow quick replacement of damaged or operated sprinklers. Prior to installation, sprinklers should be maintained in their original cartons and packaging until used to minimize the potential for damage to sprinklers that would cause improper operation or non-operation.

*DuPont Registered Trademark

Model DH56 Quick Response Extended Coverage Horizontal Sidewall Sprinkler Specification

Sprinklers shall be a [quick response – cULus Listed] extended coverage horizontal sidewall sprinkler for light hazard occupancies. Sprinklers to be of bronze frame construction with a special deflector capable of providing a discharge over a coverage area of 28 ft. (8,5m) wide, and 10 ft. (3m) long horizontal throw. Water seal assembly shall consist of a Teflon-coated Belleville spring washer and machined brass cup with 3 mm glass bulb containing no plastic parts. Installation shall permit sprinkler deflectors to be positioned 4" (102mm) to 12" (305mm) below the ceiling. Sprinklers shall have a nominal K-factor of 5.6 (80), and 1/2" NPT thread. Sprinkler temperature rating shall be [155°F (68°C)][200°F (93°C)]. Rated working pressure shall be 250 psi (17.2 bar). Standard finish: [white][chrome][bronze][Special finish– specify]. Quick response horizontal sidewall sprinklers shall be Reliable Model DH56, SIN RA1564 (Bulletin 015).

For recessed horizontal sidewall sprinklers: Replace "horizontal sidewall" with "recessed horizontal sidewall." Add: (1) Recessed escutcheon assembly shall be a two-piece escutcheon of push-on and thread off design with 1/2" (13mm) adjustment. Standard finish shall be [chrome] [white]; or (2) Recessed escutcheon assembly shall be a two-piece "friction fit" escutcheon with 1/2" adjustment. Standard finish: [white][chrome][bright brass][Special finish– specify]. Quick response recessed horizontal sidewall sprinklers shall be Reliable Model DH56, SIN RA1564 (Bulletin 015).

For concealed horizontal sidewall sprinklers: Replace "horizontal sidewall" with "concealed horizontal sidewall." Add: Cover plate assembly shall consist of a brass cover plate and copper alloy retainer flange. Method of attaching the cover plate to the sprinkler cup shall be a push-on and thread-off design allowing a 1/2" (13mm) cover plate adjustment. Cover plate temperature rating shall be 135°F (57°C) for 155°F (68°C) sprinkler and 165°F (74°C) for 200°F (93°C)

sprinkler. A plastic protective cap shall be provided and factory installed inside the sprinkler cup to protect the sprinkler from damage, which could occur during construction before the cover plate is installed. Standard cover plate finish: [white] [Custom Color– specify]. Quick response concealed horizontal sidewall sprinklers shall be Reliable Model DH56, SIN RA1564 (Bulletin 015).

UL Listing Category

Sprinklers, Automatic and Open.

Quick Response Sprinklers.

Installation Wrench

Model GFR2 Sprinkler Wrench

Note: A leak tight 1/2" NPT (R1/2) sprinkler joint can be obtained with a torque of 8-18 ft-lbs (10.8-24.4 N-m). Do not tighten sprinklers over maximum recommended torque. It may cause leakage or impairment of the sprinklers.

Installation Aid

For concealed, a protective plastic cap is included for use during installation.

Finishes ⁽¹⁾

| Standard Finishes ⁽¹⁾ | | | |
|--|---------------|----------------------------|-------------|
| Sprinkler | FP Escutcheon | F2 Escutcheon | Cover Plate |
| White or Black Polyester ⁽²⁾ / Chrome/ Bronze | White/Chrome | White/Chrome/ Bright Brass | White |

⁽¹⁾ Other colors and finishes are available. Consult factory for details.

⁽²⁾ cULus Corrosion Resistant Sprinklers.

Note: Paint or any other coatings applied over the factory finish will void all approvals and warranties.

Escutcheon Data:

FP cup/escutcheon assembly - 1/2" (13mm) adjustment

F2 - 1/2" (13mm) adjustment

Ordering Information Specify:

- DH56
- Sprinkler Finish
- DH56 Recessed
-Sprinkler Finish
- FP or F2 Escutcheon
-Escutcheon Finish
- SWC Concealed
-Cover-Plate Finish
- Protective cap for use with F2 escutcheons

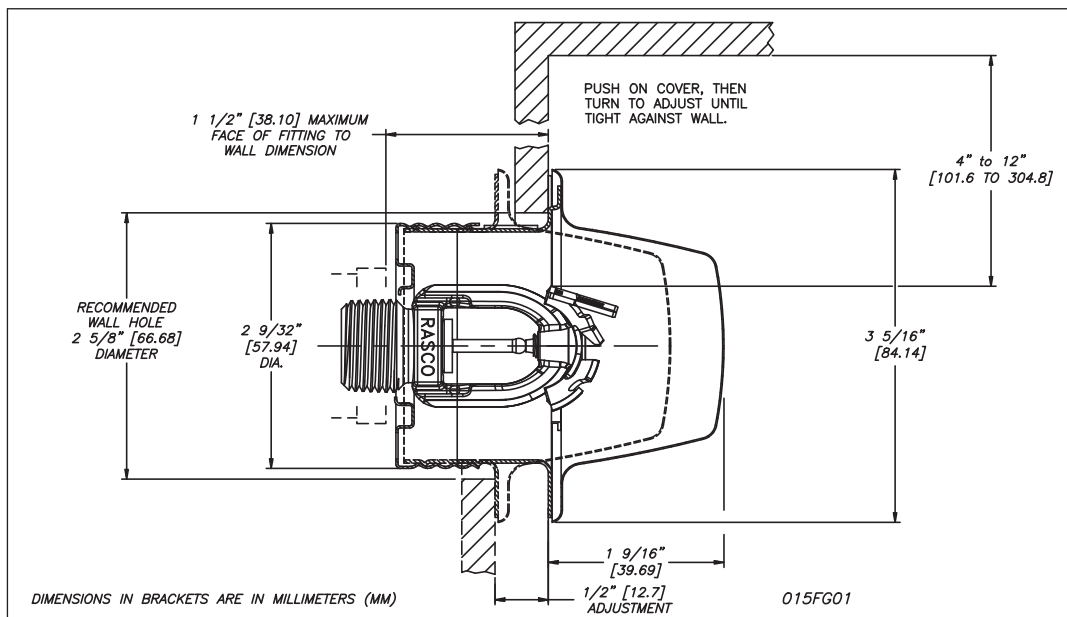

Figure 1.

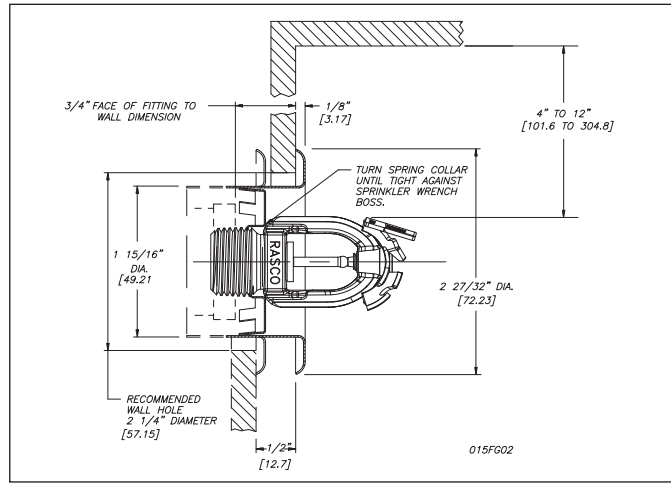

Figure 2.

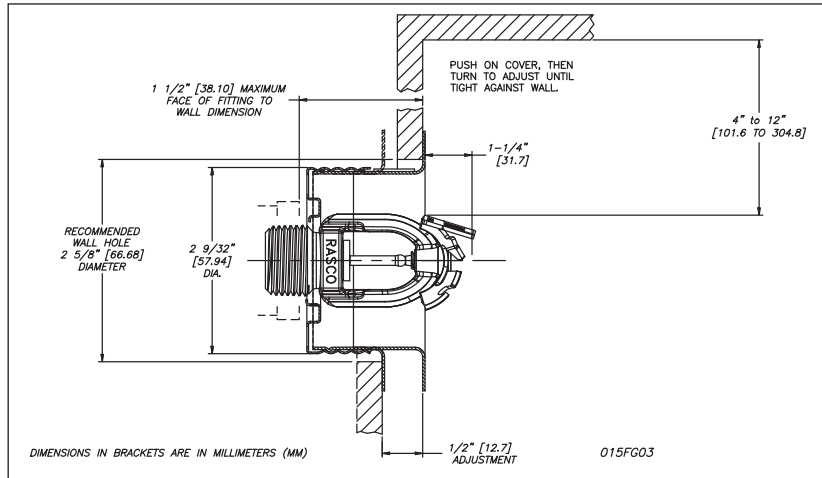

Figure 3.

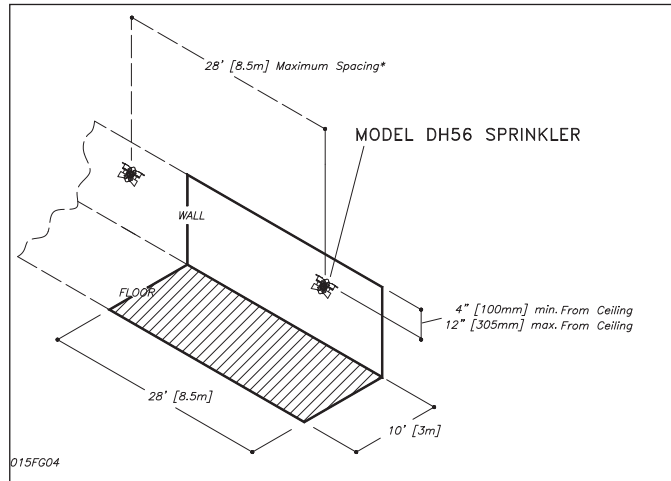

Figure 4.

The equipment presented in this bulletin is to be installed in accordance with the latest published Standards of the National Fire Protection Association, Factory Mutual Research Corporation, or other similar organizations and also with the provisions of governmental codes or ordinances whenever applicable. Products manufactured and distributed by Reliable have been protecting life and property for over 90 years, and are installed and serviced by the most highly qualified and reputable sprinkler contractors located throughout the United States, Canada and foreign countries.

Manufactured by



The Reliable Automatic Sprinkler Co., Inc.

(800) 431-1588

(800) 848-6051

(914) 829-2042

www.reliablesprinkler.com

Sales Offices

Sales Fax

Corporate Offices

Internet Address



Revision lines indicate updated or new data.

EG. Printed in U.S.A 08/10

P/N 9999970307